

# WDX Multistage Ring Section Pump

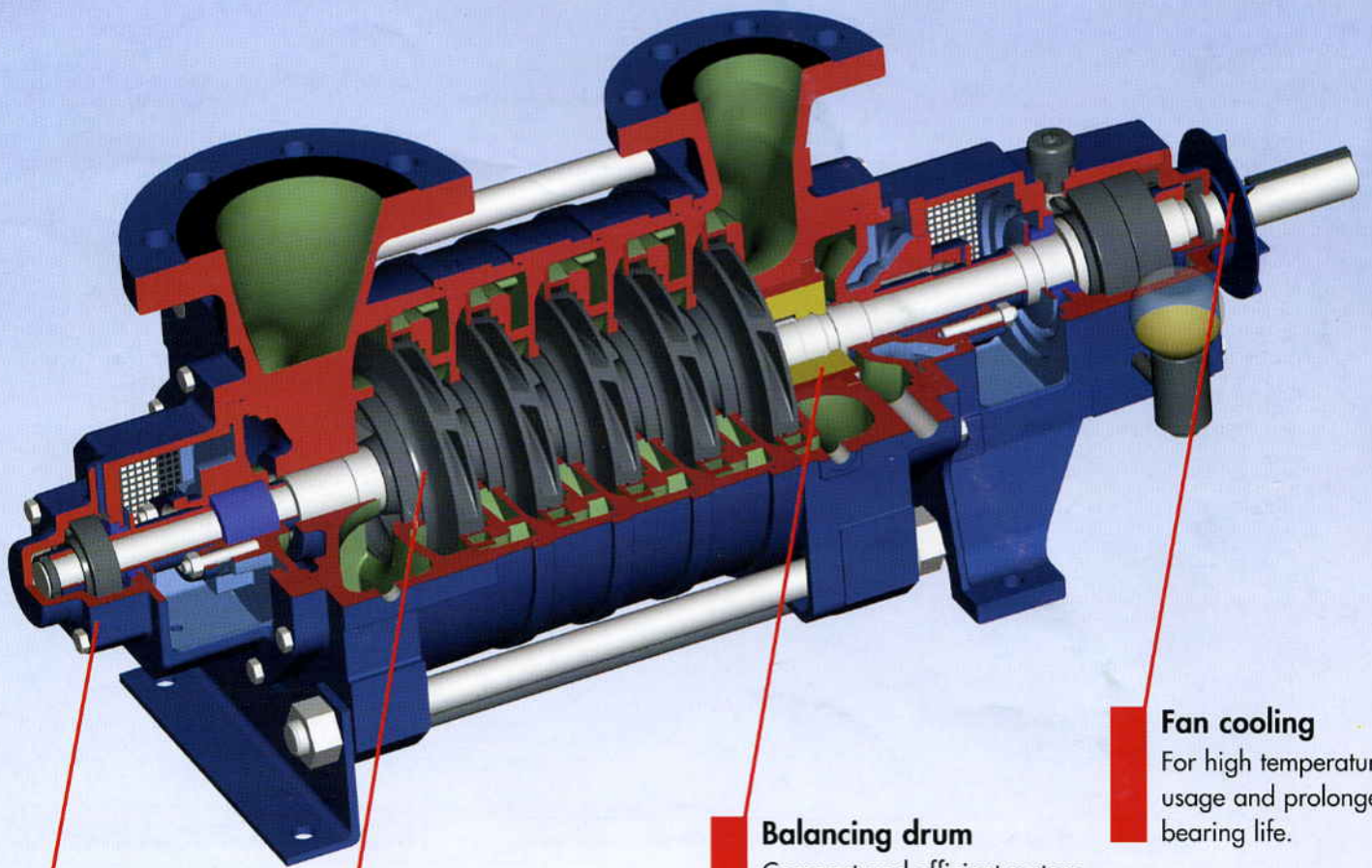

**Oil or grease lubrication**

**First stage suction impeller**  
Designed with large eye area  
to optimize NPSH characteristics.

**Balancing drum**  
Compact and efficient system  
to balance axial thrust.

**Fan cooling**  
For high temperature  
usage and prolonged  
bearing life.

**Multiple configurations**  
WDXE: End suction.  
WDXR / WDXC / WDXS: Radial suction.

**Multiple materials**  
Seven standard material columns.

# Hydraulic Coverage

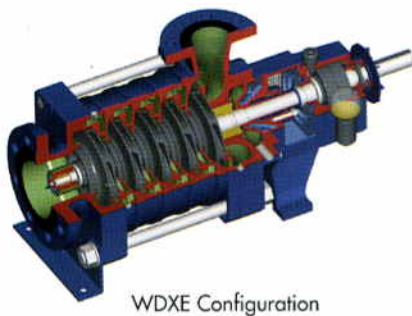

WDXE Configuration

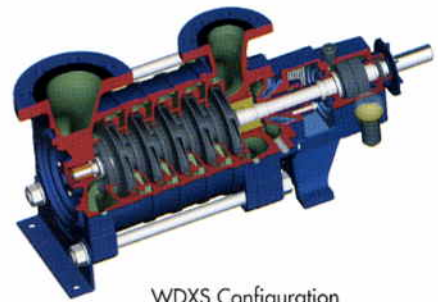
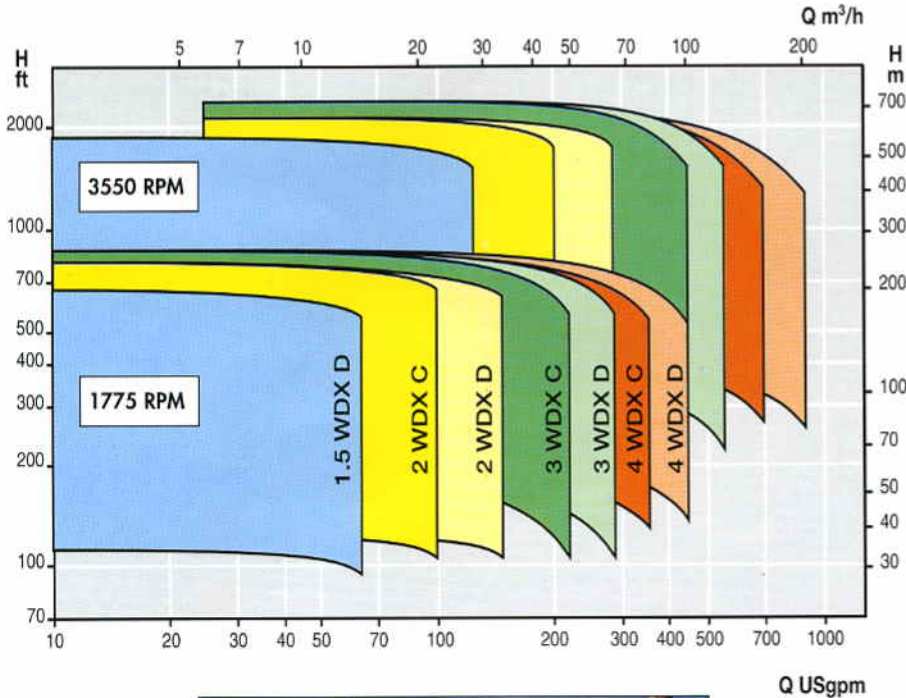
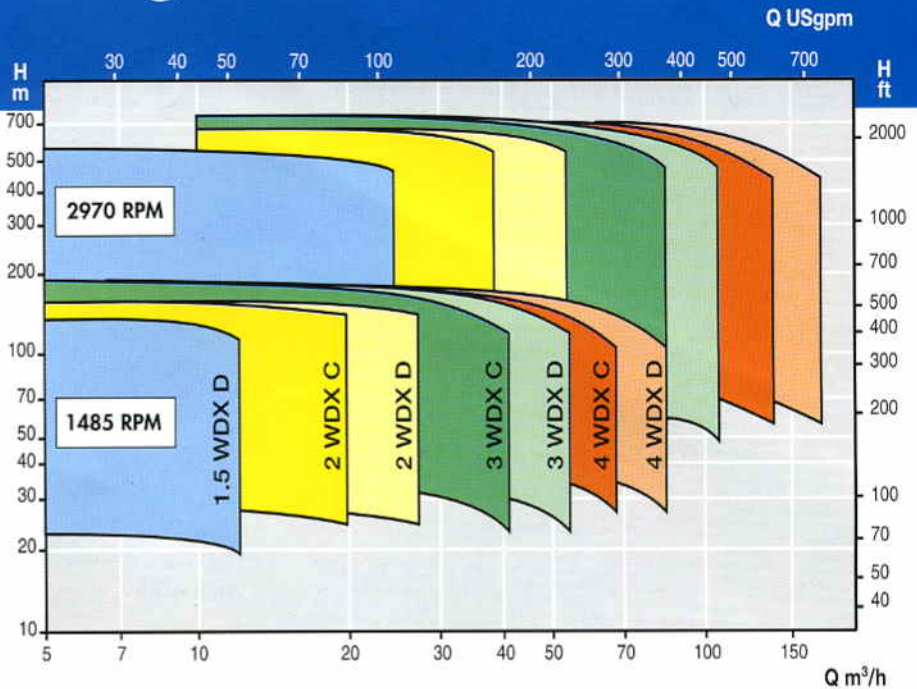

WDXS Configuration



## TYPICAL APPLICATIONS

### General Industry and OEM

- Boiler feed
- Condensate return
- Brackish water
- Pressure boosting
- High pressure cleaning
- Car wash systems
- Snow making
- Hydrocarbon transfer
- Chemical end product transfer



# WDX - High Performance Pumps

## DESCRIPTION

The WDX horizontal ring-section multistage pump is a product of over two centuries of combined pump design experience. Ingersoll-Dresser Pumps designed the WDX to perform on a wide range of high head / low flow applications. The WDX is offered with extensive hydraulic coverage, multiple material options, and a wide range of pump sizes and stages.

The heart of the WDX is the high head-per-stage impeller combined with the precision balance drum. Its compact design together with high efficiency hydraulics provide premium performance with fewer pump stages, resulting in lower installation and operation costs. The precision machined diffusers enhance this efficiency and ensure consistently reliable performance. In addition, the innovative first stage suction impeller allows reliable operation on tough, low NPSH<sub>A</sub> applications.

The application flexibility of the WDX is enhanced by its multiple configurations. The WDX is available with both radial suction and end suction arrangements. For additional adaptability, the radial discharge and suction flanges are each rotatable in 90° increments, and are available in both metric and ANSI dimensions.

By offering an extensive selection of materials, the WDX is the choice for most applications. The WDX is offered in Cast Iron, Ductile Iron, Carbon Steel, 12 % Chrome Steel, 316 Stainless Steel, and Duplex Stainless Steel.

## NOMENCLATURE

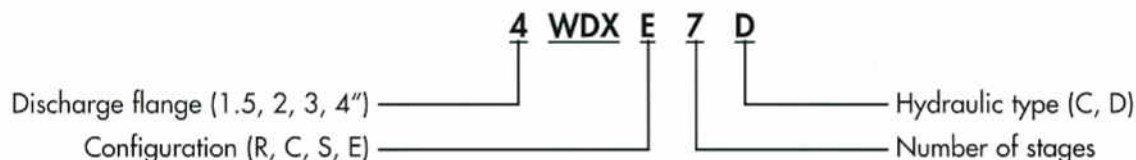

## OPERATING LIMITS

Capacity at 50 cycle up to	660 USgpm	160 m <sup>3</sup> /h
Capacity at 60 cycle up to	800 USgpm	190 m <sup>3</sup> /h
Suction pressure up to	365 psi	25 bar
Discharge pressure up to	1090 psi	75 bar
Pumping temperature up to	410° F	210° C
Maximum speed	3600 RPM	

Limits, depending on pump size, material column, and temperature.

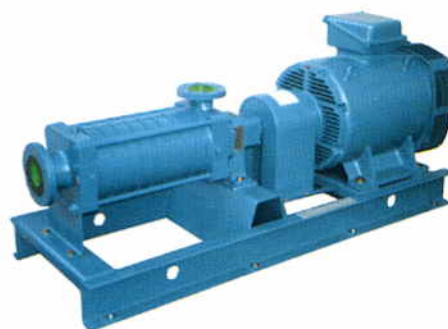

## MATERIALS OF CONSTRUCTION

Parts	Material Column						
	M 1	M 2	M 3	M 4	M 5	M 6	M 7
Casing	Cast Iron	Ductile Iron	Carbon Steel	Carbon Steel	12 % Cr Steel	SS Duplex	SS 316
Diffuser	Cast Iron	Cast Iron	Cast Iron	SS 316	SS 316	SS 316	SS 316
Impeller	Cast Iron	Cast Iron	Cast Iron	SS 316	SS 316	SS 316	SS 316
Shaft	13 % Cr Steel	13 % Cr Steel	13 % Cr Steel	13 % Cr Steel	13 % Cr Steel	SS Duplex	SS Duplex
Shaft Sleeve	13 % Cr Steel	13 % Cr Steel	13 % Cr Steel	13 % Cr Steel	13 % Cr Steel	SS 316	SS 316
Bearing Housing	Cast Iron	Cast Iron	Cast Iron	Cast Iron	Cast Iron	Cast Iron	Cast Iron
Balance Drum	Ductile Iron	Ductile Iron	Ductile Iron	Stainless Steel	Stainless Steel	Stainless Steel	Stainless Steel
Balance Ring	Ductile Iron	Ductile Iron	Ductile Iron	12 % Cr Steel	12 % Cr Steel	SS 316	SS 316

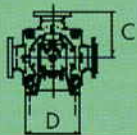
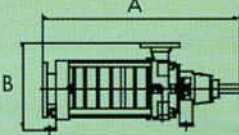
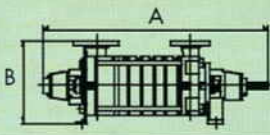
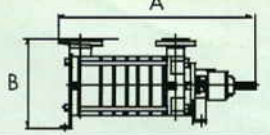

# Dimensions

			WDXE				WDXR / WDXC				WDXS				
<b>Suction flange:</b> <b>Discharge flange:</b> <b>Shaft sealing:</b> <b>Thrust bearing:</b> <b>Line bearing:</b> <b>Drive end:</b>  <b>Rotation:</b>			End Radial, rotatable in 90° increments One seal, packing or mechanical Ball bearings Product lubricated sleeve bearing At discharge side  Clockwise				Radial, rotatable in 90° increments Radial, rotatable in 90° increments Two seals, packing or mechanical Ball bearings Roller bearing WDXR at discharge side WDXC at suction side WDXR clockwise WDXC counter-clockwise				Radial, rotatable in 90° increments Radial, rotatable in 90° increments One seal, packing or mechanical Ball bearings Product lubricated sleeve bearing At discharge side  Clockwise				
															
	Max. RPM	N° of stages													
			A	B	C	D	A	B	C	D	A	B	C	D	
1.5 WDX	3600	3	623	360	180	250	888	360	180	250	653	360	180	250	
	3600	4	669	360	180	250	934	360	180	250	699	360	180	250	
	3600	5	715	360	180	250	980	360	180	250	745	360	180	250	
	3600	6	761	360	180	250	1026	360	180	250	791	360	180	250	
	3600	7	807	360	180	250	1072	360	180	250	837	360	180	250	
	3600	8	853	360	180	250	1118	360	180	250	883	360	180	250	
	3000	9	899	360	180	250	1164	360	180	250	929	360	180	250	
	3000	10	945	360	180	250	1210	360	180	250	975	360	180	250	
	3000	11	991	360	180	250	1256	360	180	250	1021	360	180	250	
	3000	12	1037	360	180	250	1302	360	180	250	1067	360	180	250	
	2 WDX	3600	3	671	415	215	270	925	415	215	270	708	415	215	270
		3600	4	724	415	215	270	978	415	215	270	761	415	215	270
3600		5	776	415	215	270	1030	415	215	270	813	415	215	270	
3600		6	829	415	215	270	1083	415	215	270	866	415	215	270	
3600		7	881	415	215	270	1135	415	215	270	918	415	215	270	
3600		8	934	415	215	270	1188	415	215	270	971	415	215	270	
3000		9	986	415	215	270	1240	415	215	270	1023	415	215	270	
3000		10	1039	415	215	270	1293	415	215	270	1076	415	215	270	
3000		11	1091	415	215	270	1345	415	215	270	1128	415	215	270	
3000		12	1144	415	215	270	1398	415	215	270	1181	415	215	270	
3 WDX		3600	3	765	465	240	309	1013	465	240	309	808	465	240	309
		3600	4	828	465	240	309	1076	465	240	309	871	465	240	309
	3600	5	891	465	240	309	1139	465	240	309	934	465	240	309	
	3600	6	954	465	240	309	1202	465	240	309	997	465	240	309	
	3600	7	1017	465	240	309	1265	465	240	309	1060	465	240	309	
	3000	8	1080	465	240	309	1328	465	240	309	1123	465	240	309	
	3000	9	1143	465	240	309	1391	465	240	309	1186	465	240	309	
	3000	10	1206	465	240	309	1454	465	240	309	1249	465	240	309	
	4 WDX	3600	3	828	520	270	340	1105	520	270	340	917	520	270	340
		3600	4	903	520	270	340	1180	520	270	340	992	520	270	340
3600		5	978	520	270	340	1255	520	270	340	1067	520	270	340	
3000		6	1053	520	270	340	1330	520	270	340	1142	520	270	340	
3000		7	1128	520	270	340	1405	520	270	340	1217	520	270	340	
3000		8	1203	520	270	340	1480	520	270	340	1292	520	270	340	

Dimensions in mm.

## Ingersoll-Rand - Pacific - Worthington - Pleuger - Scienco - Jeumont-Schneider Pumps

Nothing contained in this brochure is intended to extend any warranty or representation, expressed or implied, regarding the products described herein. Any such warranties or other terms and conditions of sale of products shall be in accordance with Ingersoll-Dresser Pumps's standard terms and conditions of sale for such products, which are available upon request.

We reserve the right to amend designs without notice.

 **Ingersoll-Dresser Pumps**

Information Centres:  
 North America Tel: (1)800.728.7867  
 Latin America Tel: (1)713.803.4400  
 Africa, Europe,  
 Middle-East Tel: (44)1204.690.524  
 Asia Tel: (65)775.3003

Representative: